

# DURACELL®



Learn more and buy it at: <https://batteryspecialties.com>

## MN1300

### Size: D (LR20)

#### Alkaline-Manganese Dioxide Battery



## COPPERTOP

Zn/MnO<sub>2</sub>



|                             |   |
|-----------------------------|---|
| Nominal voltage             | 1.5 V                                       |
| Impedance                   | 136 m-ohm @ 1 kHz                           |
| Typical weight              | 139 g (4.9 oz)                              |
| Typical volume              | 56.4 cm <sup>3</sup> (3.4 in <sup>3</sup> ) |
| Terminals                   | Flat  |
| Storage temperature range   | 5°C to 30°C (41°F to 86°F)                  |
| Operating temperature range | -20°C to 54°C (-4°F to 130°F)               |
| Designation                 | ANSI: 13A IEC: LR20                         |

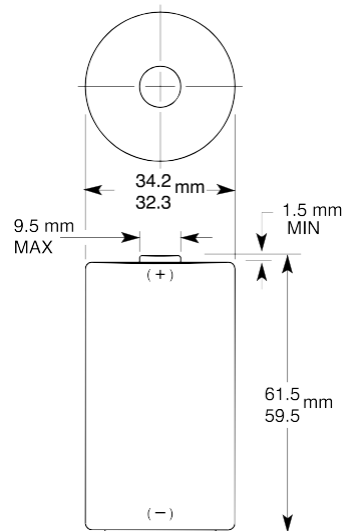

Dimensions shown are IEC standards

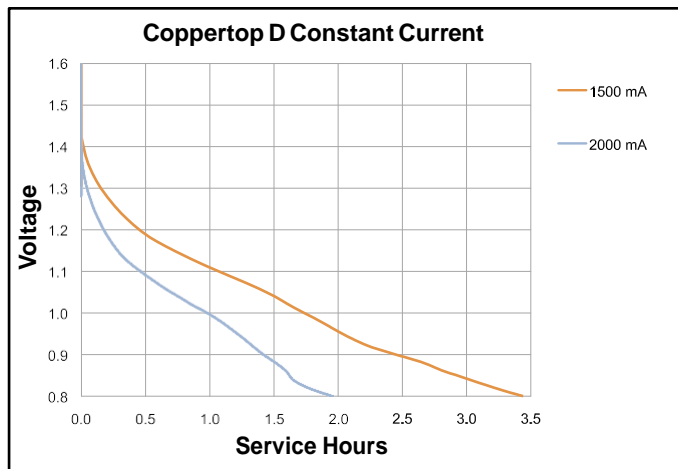
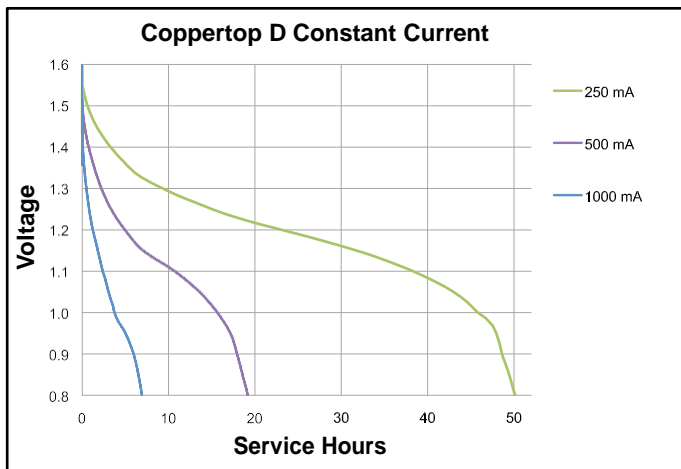

# DURACELL®

BATTERIES

Berkshire Corporate Park  
Bethel, CT. 06801 U.S.A.  
Telephone: Toll-free 1-800-544-5454  
[www.duracell.com](http://www.duracell.com)

Delivered capacity is dependent on the applied load, operating temperature and cut-off voltage. Please refer to the charts and discharge data shown for examples of the energy/service life that the battery will provide for various load conditions.

# DURACELL®



## COPPERTOP

# MN1300

## Size: D (LR20)

### Alkaline-Manganese Dioxide Battery

Zn/MnO<sub>2</sub>

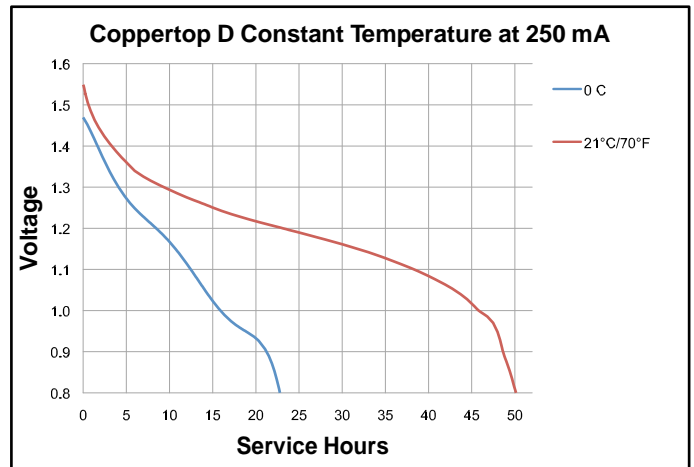
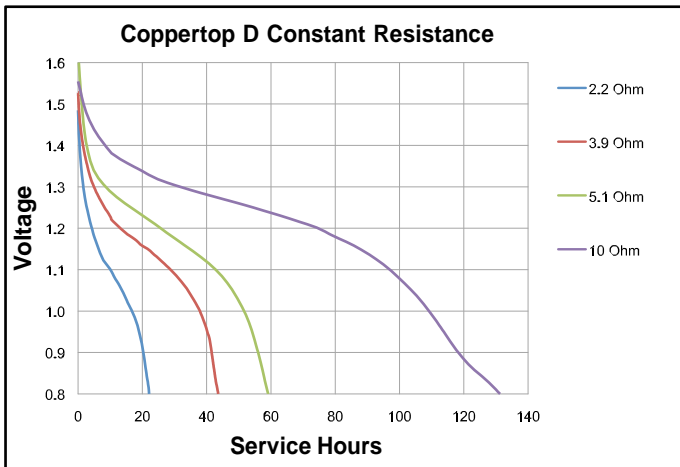
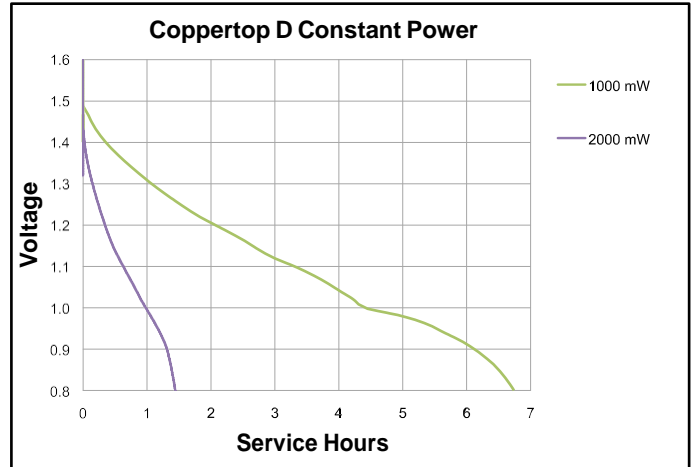
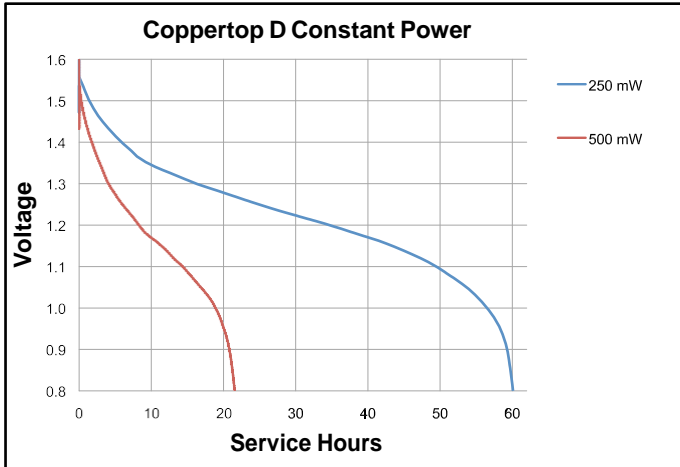

# DURACELL®

BATTERIES

Berkshire Corporate Park  
Bethel, CT. 06801 U.S.A.  
Telephone: Toll-free 1-800-544-5454  
www.duracell.com

Delivered capacity is dependent on the applied load, operating temperature and cut-off voltage. Please refer to the charts and discharge data shown for examples of the energy/service life that the battery will provide for various load conditions.